

A Series Double-column Pallet Stackers Mini Range II

with capacities of 1,200 to 1,500kg



Hangcha Europe GmbH

Mariechen-Graulich-Straße 12a,
65439 Flörsheim am Main,
Germany

Administration
Tel: 0049-61453769188
E-mail: admin@hangchaeurope.com

Sales Management
Thomas Dittrich
Mob: 0049-16096548808
E-mail: thomas.dittrich@hangchaeurope.com

Technical Support
Thomas Pannke
Mob: 0049-01759284213
E-mail: thomas.pannke@hangchaeurope.com

www.hangchaeurope.com



Folgen Sie uns auf
Instagram



Folgen Sie uns auf
Facebook



Folgen Sie uns auf
YouTube



"Hangcha Forklift"
App herunterladen



ISO14001
ISO14001:2015



ISO9001
ISO9001:2015



HANGCHA trucks conform
to the European Safety
Requirements.

2024 VERSION 7CDPRIGHT 2024/10

HANGCHA Group Co., LTD behält sich das Recht vor, Änderungen bezgl. Farbe, Spezifikationen, Ausstattung und sonstige Details, dieser Broschüre ohne Vorankündigung vorzunehmen. Fahrzeugfarben können von den Farben in dieser Brochure abweichen.

The World of Hangcha
SINCE 1956



A Series Double-column Pallet Stackers Mini Range II

The A series 1.2t/1.5t mini stackers is a new generation of products designed by Hangcha for warehousing and logistics applications. Using the latest permanent magnet drive technology and with advanced performance, comfortable, safe and reliable operations and low costs, the products are ideal tools for loading, unloading and handling palletized goods in warehouses, supermarkets, workshops and homes.



Appearance

- / The new generation of A series double-column pallet stackers mini range II adopts a professional industrial exterior design. The vehicle has a smooth vivid profile, a compact shape and a fully ergonomic design, and follows the latest exterior design trend.
- / With a large number of steel plate stamping and injection molding processes to enable a robust and durable high-grade product that meets environmental protection requirements.

Comfort

- / With the compact and stylish tiller, all operations can be easily completed with one hand.
- / The optimized design of the body structure provides an excellent operating view and to get in/out the pallet more easily.
- / Thanks to the compact, lightweight and flexible, it can be operated very easily and can pass through narrow aisles.
- / The truck can be operated in narrow space with the upright walking.
- / Gel battery: a maintenance-free battery.
- / The built-in charger is very convenient.

Safety

- / With the functions of release braking, reverse braking and emergency braking to ensure safe driving.
- / With protection for preventing sliding down a ramp to ensure safe operation.
- / The emergency reverse button on the top of the tiller can effectively prevent the driver from being injured in an emergency occurring.
- / Soft landing system can automatically slow down the lowering speed and effectively protect the goods. (only available for duplex mast)

High performance

- / With high power and a rated load capacity to meet the handling needs of most customers.
- / With a permanent magnet brush/synchronous motor with excellent performance and low heat generation.
- / The truck with regenerative braking provides protection for preventing sliding down a ramp.
- / The A2MJ model uses a permanent magnet brush controller with mature technology, and a motor with good universality and a low cost.
- / The A2MA model uses a permanent magnet synchronous controller with advanced technology, and a maintenance-free brushless motor with excellent performance.
- / The mast is made of special steel, and the outer mast is a welded structure, which reduces the weight of the vehicle and increases the rigidity.



The multi-function tiller is integrated with a code lock, display instruments and all operating buttons

Reliability

- / The bearing wheel adopts a clamping plate structure, which can adapt to uneven roads and improve the service life of the bearing wheel.
- / With a high-strength steel frame structure, the truck has a large residual load capacity and a long service life.
- / The truck with four-point design provides good road holding ensure high stability and a good view.
- / The whole system uses waterproof connectors, and all wires and cables have reliable protection, which greatly improves the reliability of the electrical system.
- / With a superior low noise and low vibration hydraulic power unit to enable stable and reliable lifting and lowering.
- / The hydraulic unit and the frame are flexibly connected so that the vibration transmitted from the road surface to the hydraulic unit can be absorbed and the reliability of the hydraulic unit is improved greatly.
- / The stamped fork with higher strength and impact resistance, and guided fork prongs, further improve operation efficiency.



Maintenance

- / The battery indicator can duly prompt the user to charge.
- / With a rear hood that can be completely opened to expose all components and facilitate the maintenance of the truck.

Standard Specification

- / Permanent magnet brush (A2M) / permanent magnet synchronous (A2MA) motor
- / Permanent magnet brush (A2M) / permanent magnet synchronous (A2MA) controller
- / Hydraulic power unit
- / Emergency power off switch
- / PU wheel
- / Fork length: 1150mm
- / Fork interval: 560mm
- / Multi-function tiller with a code lock and display instruments
- / Horn
- / Built-in charger

Options

- / Lift height: 2.0-3.6m
- / A full range of optional fork length
- / Distance between fork-arms: 680mm
- / Reflective mirror
- / Key switch
- / Universal key switch
- / Working timing function
- / Charge interlocking
- / Gel battery: 24V/100/125Ah for 1.2t
- / Gel battery: 24V/125Ah for 1.5t

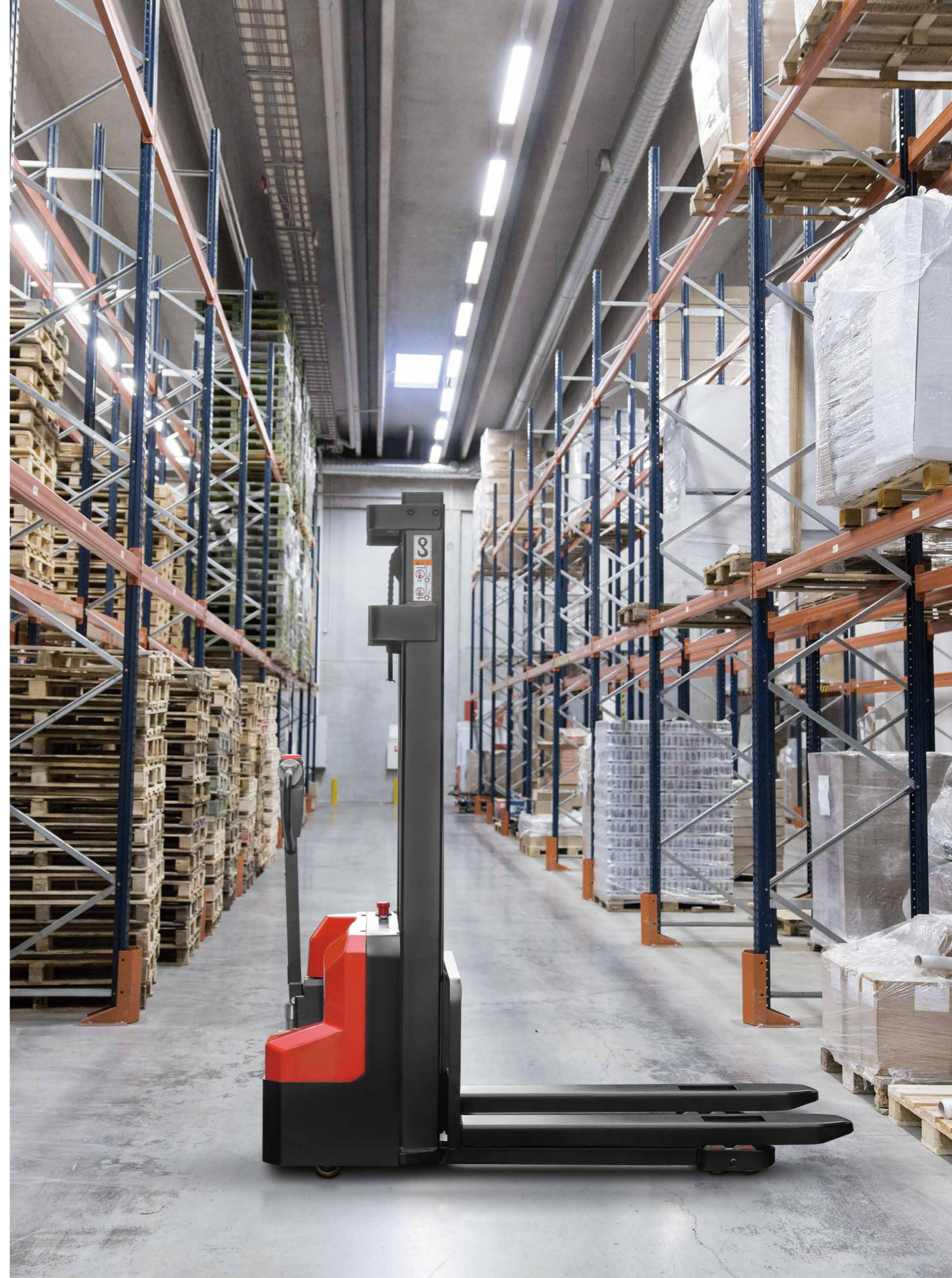

A Series Double-column Pallet Stackers Mini Range II Specification

Distinguishing mark	HANGCHA GROUP CO.,LTD.																		
	1.1	Manufacturer																	
1.2	Manufacturer's type designation																		
1.4	Operator type: hand, pedestrian, standing, seated, order-picker																		
1.5	Rated capacity/rated load																		
1.6	Load centre distance																		
1.9	Wheelbase																		
Weight	2.1	Service Weight(Including battery)																	
		Battery Weight																	
Tyres, chassis	3.1	Tyres: solid rubber, superelastic, pneumatic, polyurethane																	
	3.2	Tyre size, front																	
	3.3	Tyre size, rear																	
	3.4	Additional wheel (dimensions)																	
	3.5	Wheels, number front / rear (x = driven wheels)																	
	3.6	Tread, front																	
	3.7	Tread, rear																	
	4.4	Lift																	
Dimensions	4.9	Height drawbar in driving position min./max.																	
	4.15	Fork height,lowered																	
	4.19	Overall length																	
	4.21	Overall width																	
	4.22	Fork dimensions																	
	4.25	Distance between fork-arms																	
	4.32	Ground clearance, centre of wheelbase																	
	4.34.1	Aisle width for pallets 1000 x 1200 crossways																	
	4.34.2	Aisle width for pallets 800 x 1200 lengthways																	
	4.35	Turning radius																	
	Performance data	5.1	Travel speed,laden/unladen																
		5.2	Lift speed,laden/unladen																
5.3		Lowering speed,laden/unladen																	
5.8		Max Gradeability,laden/unladen																	
Electric Engine	6.1	Drive motor rating S2 60 min																	
	6.2	Lift motor rating at S3 15%																	
	6.4	Battery voltage, rated capacity																	
8.1	Type of drive control																		

Note: 1). VDI 2198: +284mm
2). VDI 2198: +166mm
All models are CE model

Mast Specification

Mast Type	Max Lifting Height h ₃	Max.fork height (h ₃ +h ₁₃)	Lowered Height h ₁	Extended Height h ₄	Free lift	Load Capacity at 600mm	
						1.2t	1.5t
Single cylinder duplex mast	mm	mm	mm	mm	mm	kg	kg
	2000	2085	1574	2574	0	1200	1500
	2500	2585	1824	3074	0	1200	1200
	2700	2785	1924	3274	0	1000	1000
	3000	3085	2074	3574	0	900	900
	3300	3385	2224	3874	0	750	750
3600	3685	2458	4258	0	600	600	

Straddle Leg Mast Specification

Mast Type	Max Lifting Height h ₃	Max.fork height (h ₃ +h ₁₃)	Lowered Height h ₁	Extended Height h ₄	Free lift	Load Capacity at 600mm	
						1.2t	1.5t
Single cylinder duplex mast	mm	mm	mm	mm	mm	kg	kg
	2000	2085	1593	2593	0	1200	1500
	2500	2585	1843	3093	0	1200	1200
	2700	2785	1943	3293	0	1000	1000
	3000	3085	2093	3593	0	900	900
	3300	3385	2243	3893	0	750	750
3600	3685	2471	4277	0	600	600	

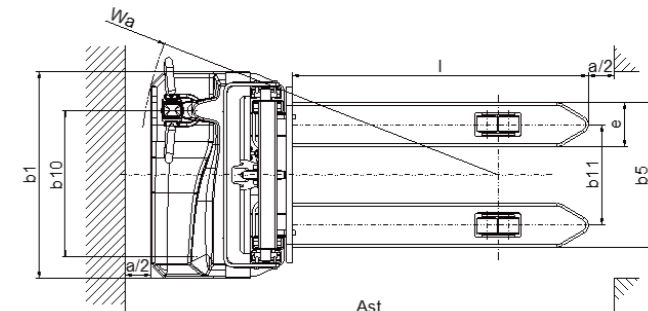
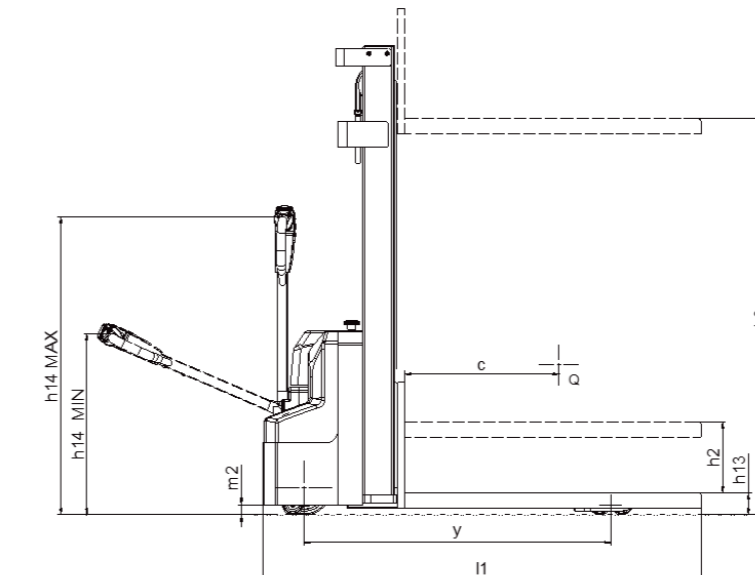
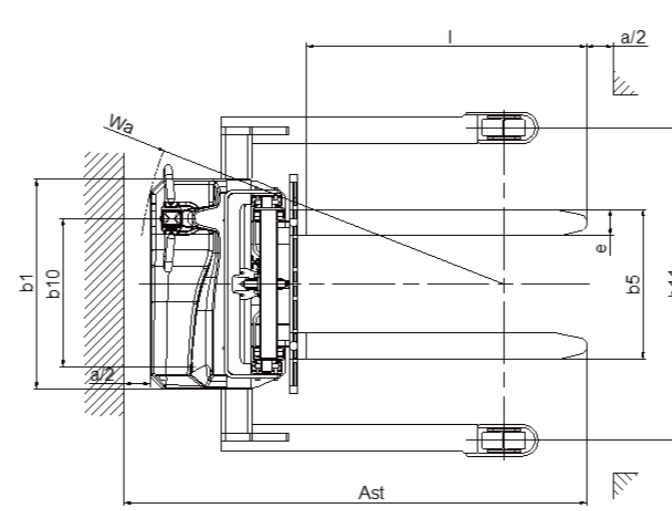
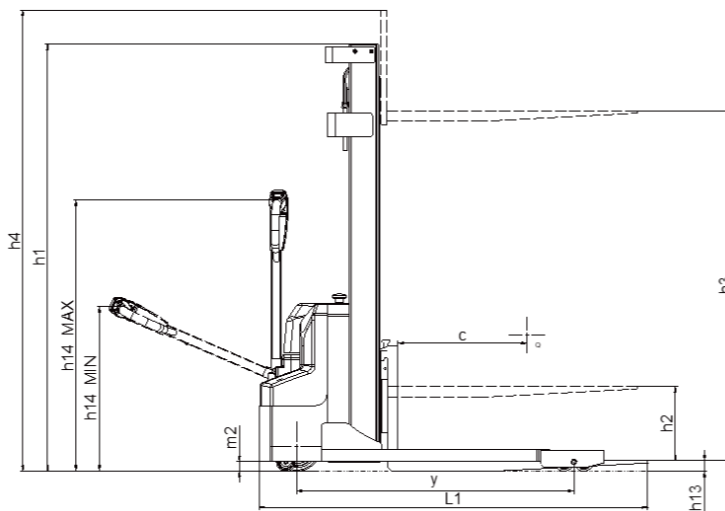

A Series Double-column Pallet Stackers Mini Range II Specification

Distinguishing mark	HANGCHA GROUP CO.,LTD.																		
	1.1	Manufacturer																	
1.2	Manufacturer's type designation																		
1.4	Operator type: hand, pedestrian, standing, seated, order-picker																		
1.5	Rated capacity/rated load																		
1.6	Load centre distance																		
1.9	Wheelbase																		
Weight	2.1	Service Weight(Including battery)																	
		Battery Weight																	
Tyres, chassis	3.1	Tyres: solid rubber, superelastic, pneumatic, polyurethane																	
	3.2	Tyre size, front																	
	3.3	Tyre size, rear																	
	3.4	Additional wheel (dimensions)																	
	3.5	Wheels, number front / rear (x = driven wheels)																	
	3.6	Tread, front																	
	3.7	Tread, rear																	
	4.4	Lift																	
Dimensions	4.9	Height drawbar in driving position min./max.																	
	4.15	Fork height,lowered																	
	4.19	Overall length																	
	4.21	Overall width																	
	4.22	Fork dimensions																	
	4.25	Distance between fork-arms																	
	4.32	Ground clearance, centre of wheelbase																	
	4.34.1	Aisle width for pallets 1000 x 1200 crossways																	
	4.34.2	Aisle width for pallets 800 x 1200 lengthways																	
	4.35	Turning radius																	
	Performance data	5.1	Travel speed,laden/unladen																
		5.2	Lift speed,laden/unladen																
5.3		Lowering speed,laden/unladen																	
5.8		Max Gradeability,laden/unladen																	
Electric Engine	6.1	Drive motor rating S2 60 min																	
	6.2	Lift motor rating at S3 15%																	
	6.4	Battery voltage, rated capacity																	
8.1	Type of drive control																		

Note: 3). VDI 2198: +343mm
4). VDI 2198: +249mm
All models are CE model